

StepArray

SA250S

DGRC Multi channel Steerable Column Loudspeaker

StepArray column loudspeakers ensure perfect speech intelligibility and optimal acoustic comfort, even in noisy and reverberant venues. They are based on the DGRC (Digital & Geometric Radiation Control) principle patented by Active Audio.

Compared with a classic sound system in which each loudspeaker is controlled independently, the DGRC makes it possible to decrease the number of channels to be controlled, thereby enhancing cost effectiveness.

It is possible to place the electronics outside the columns, which has the following key advantages:

- security: electronics can be placed in a secure room, with uninterruptible power supply (UPS)
- sharing of electronic between multiple columns
- easier installation and maintenance

StepArray column loudspeakers are driven by NUT processor and a multichannel amplifier such as MPA 8200 power amplifier. The NUT audio DSP can drive StepArray columns while also providing all the functions needed for public address systems: Automix, AGC, equalization, filtering, mixing, remote control, Speech Conformer.

In room acoustics, when column loudspeakers are highly directional, it is necessary to have several sizes of columns to fit all kind of venues.

The StepArray range offers a wide variety of listening area sizes and inclination to suit all situation.

Dedicated to step-seated audience, the SA180S model delivers up to 97dB SPL with a nominal range of 36m.



- Max SPL : 97dB at 20m
- Bandwidth : 110Hz-19kHz
- Continuous power : 300W
- IP54
- Paintable
- 5 years warranty
- For tilted audience plane

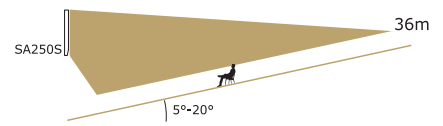

DGRC principle

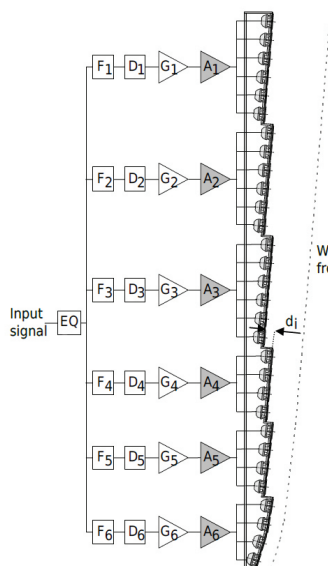

StepArray columns implement the DGRC line-array principle (Digital and Geometric Radiation control) which is a synthesis of geometric and electronic arrays patented by Active audio.

The key idea is to split the desired wave-front into sections and move them back on a vertical line, much like what is done in the Fresnel lenses used in optics. Then electronic delays are used to compensate sound propagation delay between the sections. It was shown in DGRC array that with this delay setting there is no diffraction at the edge of the saw-tooth shape. As a result of this principle, the number of DSP and amplification channels is independent of the number of loudspeakers, so that a dramatically reduced number of channels is achieved.

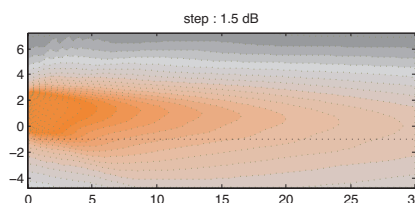

Step Array SA250S vertical directivity: sound level for the speech octaves (500Hz-1kHz-2kHz) in the vertical median plane.



SA250S

Technical Specifications

Mechanical drawing

Front views

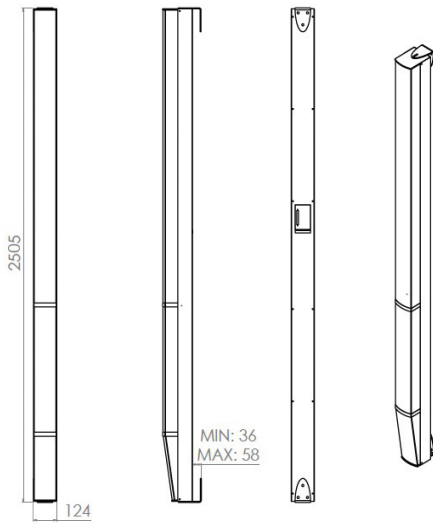

Rigging

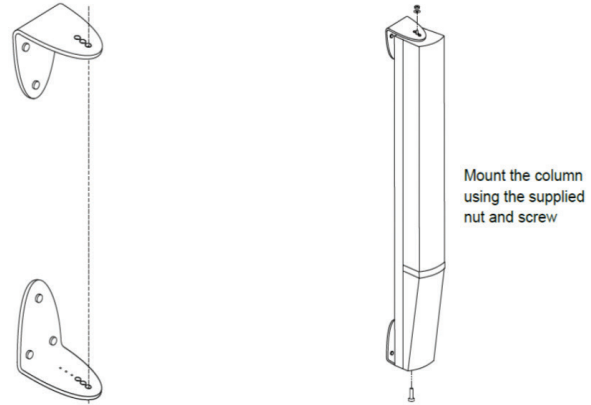

Technical Specifications

Acoustical data

| | |
|----------------------------------|-----------------------------|
| Range +/- 3dB | 35 m |
| Range +/- 5dB | 45 m |
| Max SPL | 97dB at 20m (123dB at 1m) * |
| Angle of audience | >5° |
| Frequency bandwidth (-10 dB) | 110Hz-19kHz |
| Horizontal opening angle (1 kHz) | 180° |
| Loudspeaker | 30 x3" |

Mechanical data

| | |
|-----------------|----------------------------------|
| Net weight | 24 kg |
| Shipping weight | 29 kg |
| Height | 2505 mm |
| Width | 124 mm |
| Depth | 159 mm |
| Standard colors | White RAL 9016 Black RAL 9005 |

Sound level by octave in the axis of the listening plane in front of the column with respect to the distance from the column

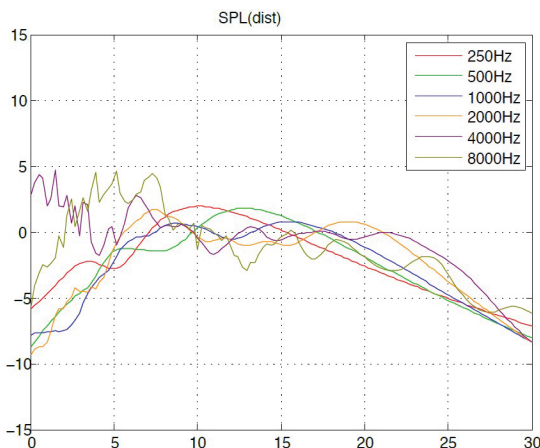

Electrical data

| | |
|----------------|--|
| Input | 12 Pins euroblock |
| Impedance | 3 channels 8Ω 3 channel 5Ω |
| Cabling lenght | <300m with 7x1,5mm ² cable <500m with 7x2,5mm ² cable |

Tunning and exploitation

| | |
|-------------------------|---|
| Software supplied | NUT software |
| Modeling | EASE and CATT Active Audio prediction software www.activeaudio.fr |
| Nominal mounting height | 2,5 m |

*Estimated sound level based on a 6dB decreased by doubling distance from the measure pressure level at 20m.

Frequency response

StepArray frequency response. Average from 5 to 20m for a column at 2.55m height and an audience area tilted by 12°.

In red: with bass high-pass on position «100Hz»,
In blue: with bass high-pass on position «200Hz»

