

StepArray

SA400P

DGRC Multi channel Steerable Column Loudspeaker

StepArray column loudspeakers ensure perfect speech intelligibility and optimal acoustic comfort, even in noisy and reverberant venues. They are based on the DGRC (Digital & Geometric Radiation Control) principle patented by Active Audio.

Compared with a classic sound system in which each loudspeaker is controlled independently, the DGRC makes it possible to decrease the number of channels to be controlled, thereby enhancing cost effectiveness.

It is possible to place the electronics outside the columns, which has the following key advantages:

- security: electronics can be placed in a secure room, with uninterruptible power supply (UPS)
- sharing of electronic between multiple columns
- easier installation and maintenance

StepArray column loudspeakers are driven by NUT processor and a multichannel amplifier such as MPA 8200 power amplifier. The NUT audio DSP can drive StepArray columns while also providing all the functions needed for public address systems: Automix, AGC, equalization, filtering, mixing, remote control, Speech Conformer.

In room acoustics, when column loudspeakers are highly directional, it is necessary to have several sizes of columns to fit all kind of venues.

The StepArray range offers a wide variety of listening area sizes and inclination to suit all situation.

Dedicated to flat horizontal areas, the SA400P model delivers up to 95dB SPL with a nominal range of 90m.



Max SPL: 97dB at 30m
Bandwidth: 110Hz-19kHz
Continuous Power: 490W
IP54
Paintable
5 years warranty
For horizontal audience



DGRC principle

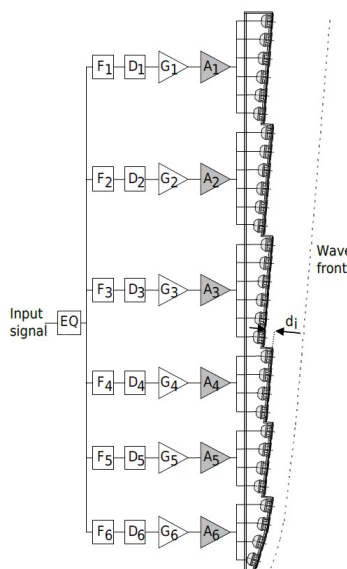

StepArray columns implement the DGRC line-array principle (Digital and Geometric Radiation control) which is a synthesis of geometric and electronic arrays patented by Active audio.

The key idea is to split the desired wave-front into sections and move them back on a vertical line, much like what is done in the Fresnel lenses used in optics. Then electronic delays are used to compensate sound propagation delay between the sections. It was shown in DGRC array that with this delay setting there is no diffraction at the edge of the saw-tooth shape. As a result of this principle, the number of DSP and amplification channels is independent of the number of loudspeakers, so that a dramatically reduced number of channels is achieved.

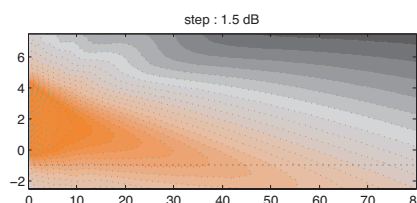

Step Array SA400P vertical directivity: sound level for the speech octaves (500Hz-1kHz-2kHz) in the vertical median plane.



SA400P

Technical Specifications

Mechanical drawing

Front views

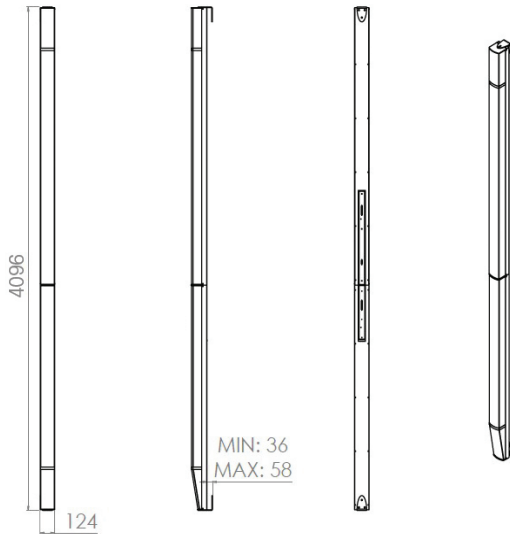

Rigging

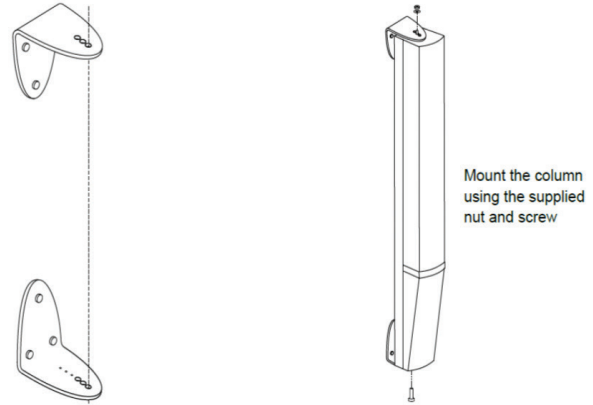

Technical Specifications

Acoustical data

Range +/- 3dB	68 m
Range +/- 5dB	90 m
Max SPL	97dB at 30m (126,5dB at 1m)*
Angle of audience	0°-5°
Frequency bandwidth (-10 dB)	110Hz-19kHz
Horizontal opening angle (1 kHz)	180°
Loudspeaker	49 x3"

Mechanical data

Net weight	39 kg
Shipping weight	46 kg
Height	4096 mm
Width	124 mm
Depth	135 mm
Standard colors	White RAL 9016 Black RAL 9005

Electrical data

Input	12 Pins euroblock
Impedance	6 channels 8Ω
Cabling lenght	<300m with 7x1,5mm ² cable <500m with 7x2,5mm ² cable

Tunning and exploitation

Software supplied	NUT software
Modeling	EASE and CATT Active Audio prediction software www.activeaudio.fr
Nominal mounting height	3,0 m

*Estimated sound level based on a 6dB decreased by doubling distance from the measure pressure level at 30m.

Sound level by octave in the axis of the listening plane in front of the column with respect to the distance from the column

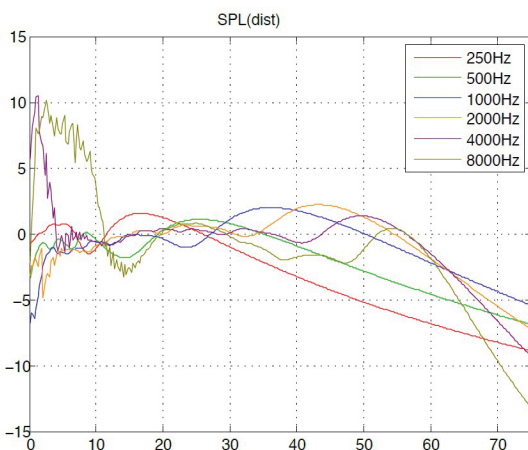

Frequency response

StepArray frequency response. Average from 10 to 45m on axis.
In red: with bass high-pass on position «100Hz»,
In blue: with bass high-pass on position «200Hz»

